

DIO3212

High-bandwidth and Low on-resistance Analog Switch

Features

- Over-Voltage Tolerance (OVT)
- Voltage Operation: 2.3V to 5V
- Low On Resistance: 3.6Ω typ at 3.0Vcc
- High Off-Isolation
- Low Crosstalk
- Low Con: 5pF
- Low power consumption
- Wide -3dB Bandwidth
- Low Distortion
- Green Packaged: QFN10, MSOP10 and DFN10
- 2KV CDM ESD Rating
8kV I/O to GND HBM ESD Rating

Applications

- Cell Phones
- PDAs and MP3s
- Portable Instrumentation
- Battery Powered Communications
- Computer Peripherals

Descriptions

The DIO3212 is a low power, dual SPDT 2-port high-speed analog switch. It handles bi-directional signal flow and is optimized for switching a high-speed (480Mbps) source.

DIO3212 has high channel-to-channel noise isolation and low bit-to-bit skew which allows it to pass high-speed differential signals with good signal integrity. Each switch offers little or no attenuation of the high-speed signals at the outputs.

The DIO3212 contains special circuitry on the D+/D- pins, which can tolerate up to 5.25V when the USB devices are either powered off or powered on.

Block Diagram

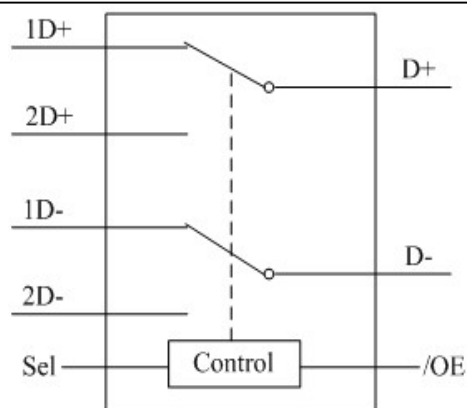

Ordering Information

Order Part Number	Top Marking		T _A	Package		
DIO3212QN10	YWGB	Green	-40 to 85°C	QFN-10(1.5*2.0*0.55mm)	MSL1	Tape & Reel, 3000
DIO3212DN10	D3212	Green	-40 to 85°C	DFN-10(3.0*3.0*0.75mm)	MSL3	Tape & Reel, 5000
DIO3212MP10	DIO3212	Green	-40 to 85°C	MSOP-10	MSL3	Tape & Reel, 3000

Pin Assignment

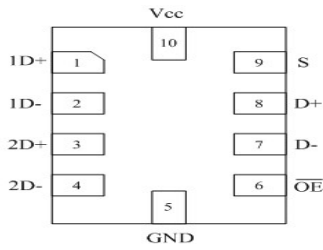

QFN-10

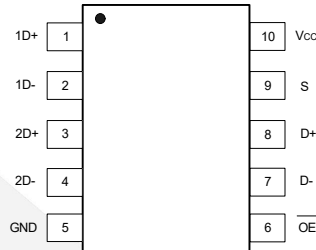

MSOP-10

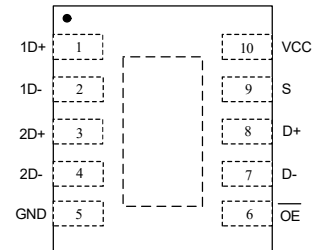

DFN-10

Figure 1 Top View

Pin Descriptions

Pin Name	Description
/OE	Switch Enable
Sel	Switch Select
V _{CC}	Power
GND	Power
D+, D-	USB Data Bus
1D+, 1D-	Multiplexed Source inputs
2D+, 2D-	Multiplexed Source inputs

Truth Table

Sel	/OE	Function
X	H	Disconnect
L	L	D to 1D
H	L	D to 2D



DIO3212

High-bandwidth and Low on-resistance Analog switch

Absolute Maximum Ratings

Stresses beyond those listed under “Absolute Maximum Rating” may cause permanent damage to the device. These are stress ratings only and functional operation of the device at these or any other condition beyond those indicated in the operational sections of the specifications is not implied. Exposure to absolute maximum rating conditions for extended periods may affect device reliability.

Symbol	Parameter	Min.	Max.	Unit
V_{CC}	Supply Voltage	-0.5	5	V
V_{SW}	DC Switch Voltage	-0.5	7	V
V_{IN}	DC Input Voltage	-0.5	7	V
$V_{D+/D-}$	D+/D- DC voltage ^(Note 1)	-0.3	9	V
I_{SW}	On-state Switch Current	-120	120	mA
	Continuous current through V_{CC} or GND	-100	100	mA
T_{STG}	Storage Temperature Range	-65	150	°C
θ_{JA}	DFN10 Package		48.7	°C/W
	QFN10 Package		243	°C/W
ESD	HBM, JEDEC: JESD22-A114 (I/O to GND)		8	kV
	CDM, JEDEC: JESD22-C101		2	

Note 1: This rating only applies to the D+/D- pin with respect to GND. V_{CC} must be powered within the recommended operating conditions of 2.3V to 5V and the OE pin must be logic high for this rating to be applicable. Any condition where V_{CC} is unpowered or the OE pin is not high must reference the rest of the Absolute Maximum Ratings Table.

Recommend Operating Conditions

The Recommended Operating Conditions table defines the conditions for actual device operation to ensure optimal performance to the datasheet specifications. DIOO does not recommend exceeding them or designing to Absolute Maximum Ratings.

Symbol	Parameter	Min.	Max.	Unit
V_{CC}	Supply Voltage	2.3	5	V
V_{IN}	Control Input Voltage	0	5.5	V
V_{SW}	Switch Input Voltage	0	5.5	V
T_A	Operating Temperature	-40	85	°C



DIO3212

High-bandwidth and Low on-resistance Analog switch

DC Electrical Characteristics

All typical value are at $T_A = 25^\circ\text{C}$ unless otherwise specified.

Symbol	Parameter	Conditions	Temp.	Min	Typ	Max	Unit
V_{IK}	Clamp Diode Voltage	$I_{IN}=-18\text{mA}$, $V_{CC}=3.0\text{V}$	-40°C to 85°C			-1.2	V
V_{IH}	Input voltage high	$V_{CC}=2.3\text{V}$ to 2.7V	-40°C to 85°C	1.3			V
		$V_{CC}=2.7\text{V}$ to 3.6V		1.5			
V_{IL}	Input voltage low	$V_{CC}=2.3\text{V}$ to 2.7V	-40°C to 85°C			0.5	V
		$V_{CC}=2.7\text{V}$ to 3.6V				0.6	
I_{IN}	Control input leakage	$V_{CC}=3.6\text{V}$, 2.7V , 0V , $V_{IN}=0\text{V}$ to 3.6V	-40°C to 85°C	-1		1	μA
I_{OFF}	V_{CC} off leakage current See Figure 3	$V_{CC}=0\text{V}$, $V_{SW}=0\text{V}$ to 3.6V	-40°C to 85°C	-2		2	μA
		$V_{CC}=0\text{V}$, $V_{SW}=0\text{V}$ to 2.7V		-1		1	
I_{CC}	Quiescent supply current	$V_{CC}=3.6\text{V}$, 2.7V , $V_{IN}=V_{CC}$ or GND, Switch ON or OFF	-40°C to 85°C			25	μA
I_{CCT}	I_{CC} current per control voltage and V_{CC}	$V_{IN}=1.8\text{V}$, $V_{CC}=3.6\text{V}$	-40°C to 85°C			28	μA
		$V_{IN}=1.8\text{V}$, $V_{CC}=2.7\text{V}$				18	
R_{ON}	Switch on Resistance See Figure 2	$V_{CC}=3.0\text{V}$	$V_{SW}=0.4\text{V}$, $I_{SW}=-8\text{mA}$	25°C	3.6	5	Ω
				-40°C to 85°C			
ΔR_{ON}	On Resistance Matching between Channels	$V_{CC}=3.0\text{V}$	$V_{SW}=0.4\text{V}$, $I_{SW}=-8\text{mA}$	25°C	0.2		Ω
				-40°C to 85°C		0.2	
$R_{FLT(ON)}$	On Resistance Flatness	$V_{CC}=3.0\text{V}$	$V_{SW}=0.4\text{V}$, $I_{SW}=-8\text{mA}$	-40°C to 85°C		1	Ω



DIO3212

High-bandwidth and Low on-resistance Analog switch

AC Electrical Characteristics

All typical value are at $V_{CC}=3.3V \pm 10\%$, $T_A=25^\circ C$ unless otherwise specified.

Symbol	Parameter	Conditions	Temp.	Min.	Typ.	Max.	Unit
T_{ON}	Turn-On Time	$V_{SW}=1.7V, R_L = 300\Omega, C_L = 35pF$, See Figure 9	$25^\circ C$		14.5		ns
T_{OFF}	Turn-Off Time	$V_{SW}=1.7V, R_L = 300\Omega, C_L = 35pF$, See Figure 9	$25^\circ C$		8.5		ns
T_{pd}	Propagation delay	$R_L=50\Omega, C_L=5pF$, See Figure 10	$25^\circ C$		0.25		ns
OIRR	Off Isolation	Signal=0dBm, f=250MHz See Figure 7	$25^\circ C$		-40		dB
				$R_L = 50\Omega, C_L = 5pF$	-35		
X_{talk}	Crosstalk	Signal=0dBm, f=250MHz See Figure 6	$25^\circ C$		-41		dB
				$R_L = 50\Omega, C_L = 5pF$	-36		
BW	-3dB bandwidth	Signal=0dBm, See Figure 5	$25^\circ C$		1		GHz
				$R_L = 50\Omega, C_L = 5pF$	650		MHz

Capacitance

Symbol	Parameter	Conditions	Temp.	Min.	Typ.	Max.	Unit
C_{IN}	Control Pin input Capacitance	$V_{CC}=3.3V, 2.5V, V_{IN}=3.3V$ or $0V$	$25^\circ C$		1		pF
C_{OFF}	OFF Capacitance	$V_{CC}=3.3V, 2.5V$ Switch Off $V_{SW}=3.3V$ or $0V$, See Figure 4	$25^\circ C$		3		pF
C_{ON}	On Capacitance	$V_{CC}=3.3V, 2.5V$ Switch On $V_{SW}=3.3V$ or $0V$, See Figure 4	$25^\circ C$		5		pF

Test Diagrams

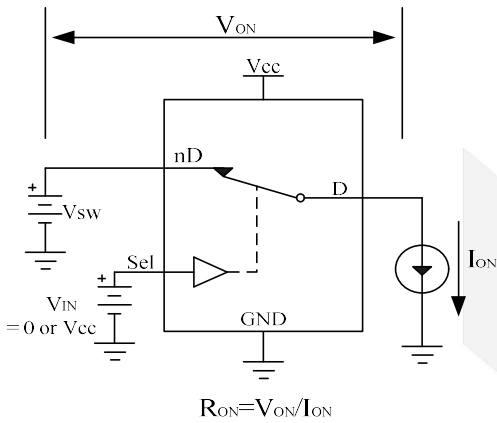

Figure 2 Switch on resistor

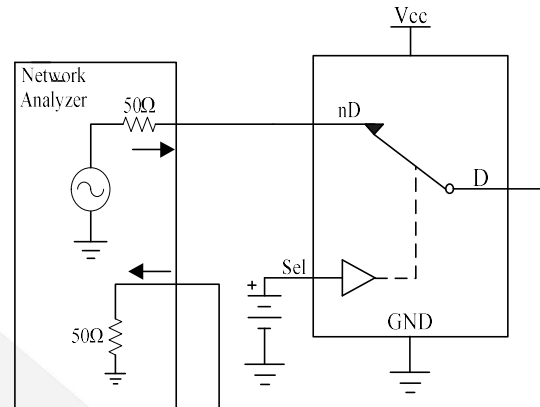

Figure 5 Bandwidth

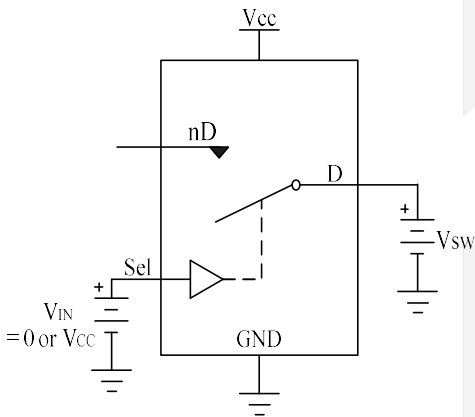

Figure 3 Switch Off Leakage

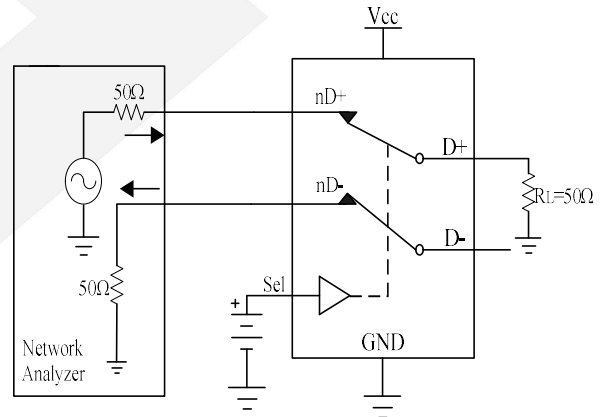

Figure 6 Channel-to-channel crosstalk

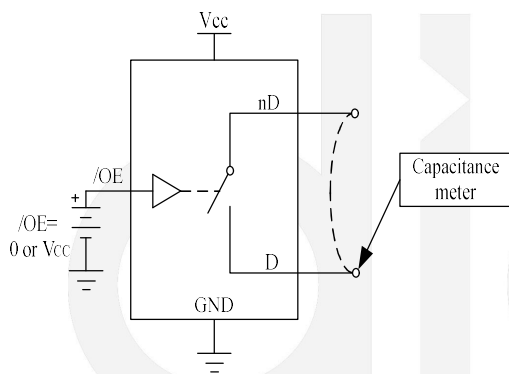

Figure 4 On/off Capacitance test

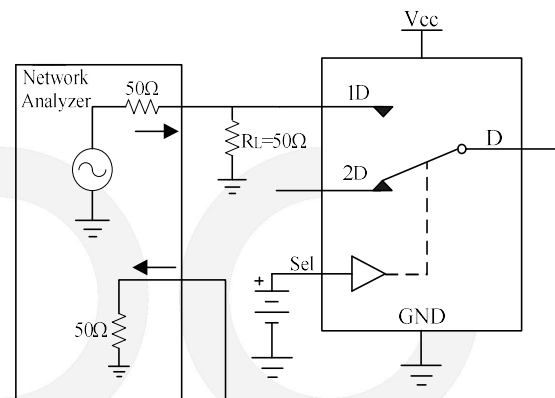

Figure 7 Off-isolation

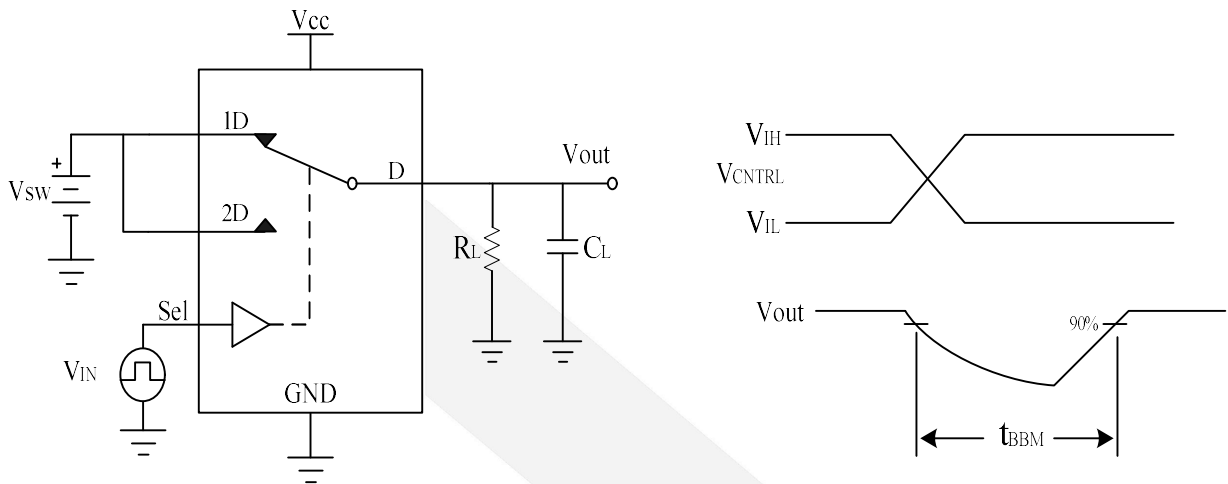

Figure 8 Break-Before-Make

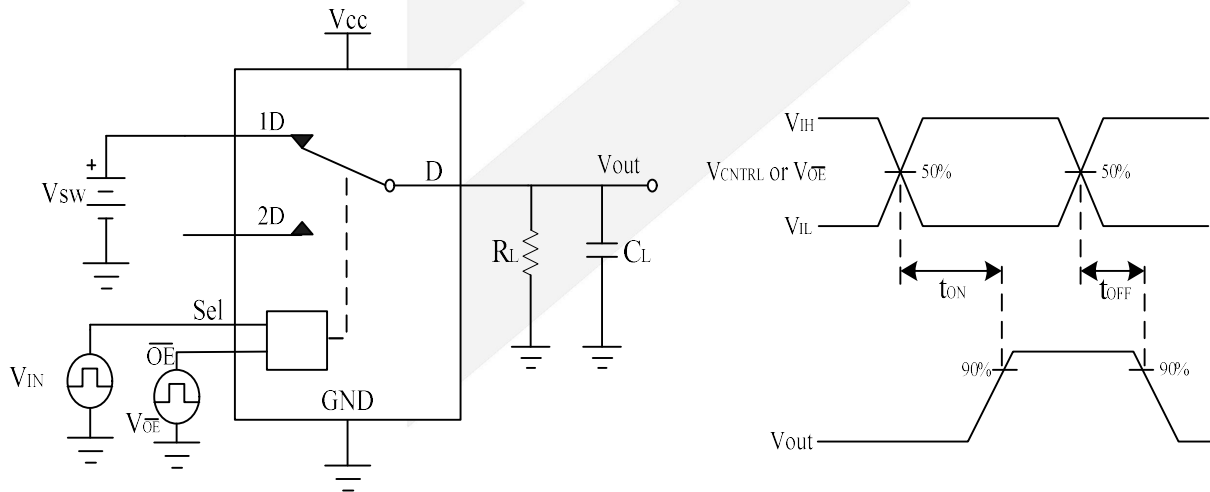

Figure 9 Turn-On/Turn-Off

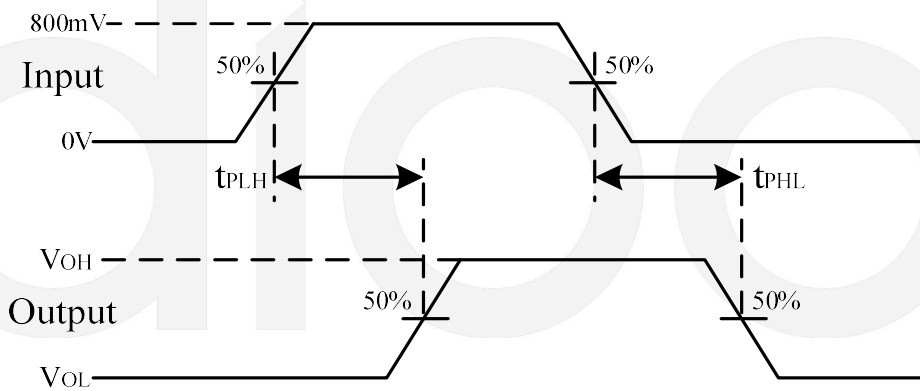

Figure 10 Propagation delay

CONTACT US

Dioo is a professional design and sales corporation for high-quality and performance analog semiconductors. The company focuses on industry markets, such as, cell phone, handheld products, laptop, and medical equipments and so on. Dioo's product families include analog signal processing and amplifying, LED drivers and charger IC. Go to <http://www.dioo.com> for a complete list of Dioo product families.

For additional product information, or full datasheet, please contact with our Sales Department or Representatives.

